



Features

- Fast response time.
- Bi-polar surge absorber, it will fail open if the surge withstand capacity is exceeded.
- Small inter-terminal capacitance.
- High insulation resistance (1X10⁹h. min).
- Excellent surge withstand capability (300times at 100A, 8X20μs).
- Small size for compact circuit design.

Applications

- xDSL modems, Splitters, BS tuner, CRT, VCR, Telephone, Modems, Car audio and GPS.

Safety Agency : Standard		File NO.
UL	UL1449,UL1414	E143446,E47474
CSA	C22.2 No.1	LR105073
TÜV	IEC60384-14	J95511033

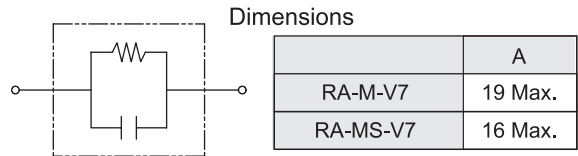
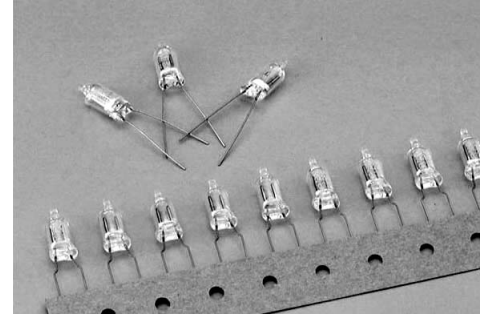
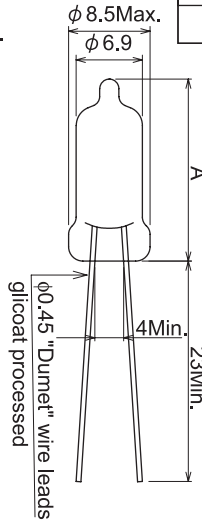

Electrical Specifications

Safety Standard				Model Number	DC Spark-over Voltage (V)	Capacitance 1kHz-1.5V (pF)	Peak Surge Current 8/20μs (A)	Impulse Life test 8/20μs 100A	Withstand Voltage Test
UL 1449	UL 1414	CSA	TÜV						
○ 1)	—	—	—	RA-501M/MS-V7	500 (400~ 600)	2.0Max.	3500	300	-
○ 1)2)	—	—	—	RA-601M/MS-V7	600 (480~ 720)				-
○ 1)2)	—	—	—	RA-102M/MS-V7	1000(800~ 1200)				-
○ 1)2)	—	—	—	RA-152M/MS-V7	1500(1200~1800)				-
○ 1)	○ 1)	○ 1)	—	RA-242M-V7	2400(1920~2880)				AC1250V 3s
○ 1)2)	○ 1)2)	○ 3)	○ 3)	RA-302M-V7	3000(2400~3600)				AC1500V 60s
○ 1)2)	○ 1)2)	○ 3)	○ 3)	RA-362M-V7	3600(2880~4320)				AC1800V 3s
○ 2)	○ 2)	—5)	○ 4)	RA-402M-V7	4000(3200~4800)				AC2000V 60s
○ 2)	○ 2)	—5)	○ 4)	RA-452M-V7	4500(3600~5400)				AC2000V 60s
○ 1)	○ 1)	—5)	—	RA-242MS-V7	2400(1920~2880)				AC1250V 3s
○ 1)2)	○ 1)2)	—5)	○ 3)	RA-302MS-V7	3000(2400~3600)				AC1500V 60s
○ 1)2)	○ 1)2)	○ 3)	○ 3)	RA-362MS-V7	3600(2880~4320)				AC1800V 3s
○ 2)	○ 2)	—	○ 3)	RA-402MS-V7	4000(3200~4800)				AC2000V 60s
○ 2)	○ 2)	○ 3)	○ 3)	RA-452MS-V7	4500(3600~5400)				AC2000V 60s

- 1) Rated voltage AC125V: Approved if it is connected to UL approved varistor (V1.0mA≥270V, D≥ φ5mm).
- 2) Rated voltage AC250V: Approved if it is connected to UL approved varistor (V1.0mA≥390V, D≥ φ7mm).
- 3) Rated voltage AC250V: Approved if it is connected to UL approved varistor (V1.0mA≥270V, D≥ φ5mm).
- 4) Rated voltage AC250V: Approved if it is connected to UL approved varistor (V1.0mA≥270V, D≥ φ10mm).
- 5) Applying

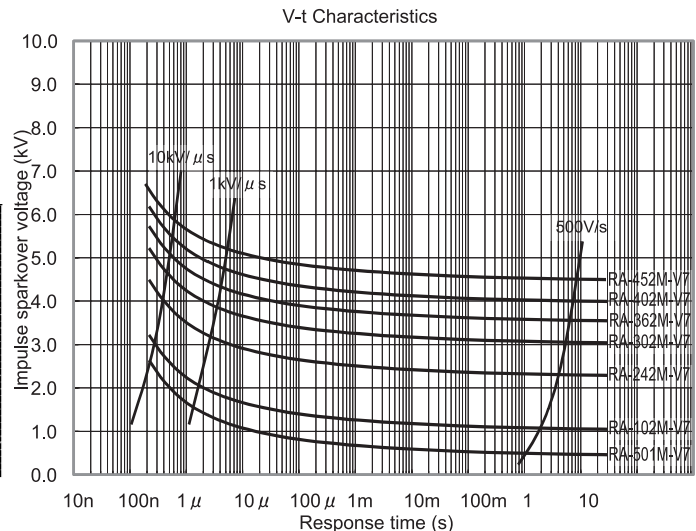
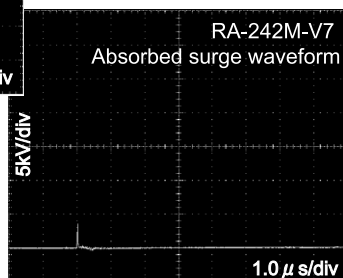
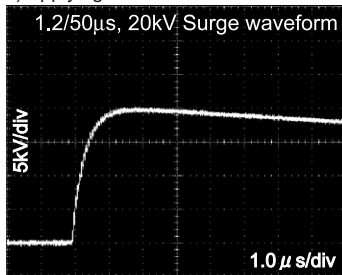



- Taping Dimensions

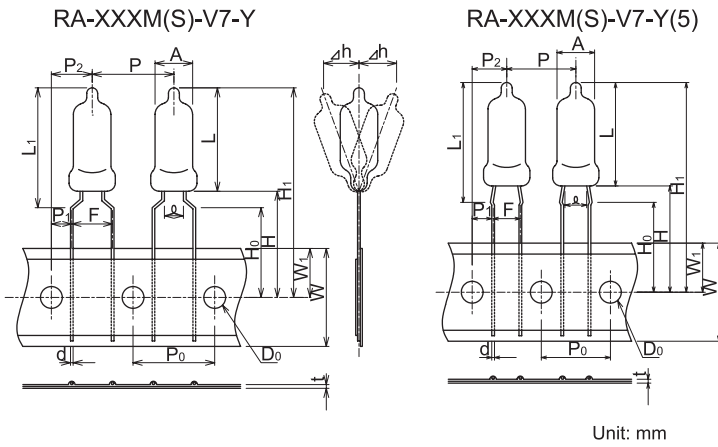

Unit: mm

Description	Symbol	Dimension	
		RA-M(S)-V7-Y	RA-M(S)-V7-Y(5)
RA	Hight	L	19.0Max. (16.0Max.)
	Lamp Diameter	A	$\phi 6.9 \pm 0.65$
	Lead Diameter	d	$\phi 0.5 \pm 0.05$
	Width between leads	ϱ	4.0Min.
Product hight from board	L1	22.0Max. (19.0Max.)	
Lamp pitch	P	15.0 \pm 1.0	12.7 \pm 1.0
Hole pitch	P0	15.3 \pm 0.3 注	12.7 \pm 0.3 注
Hole position	P1	3.75 \pm 0.7	3.85 \pm 0.7
	P2	7.5 \pm 1.3	6.35 \pm 1.3
Pitch between leads	F	7.5 \pm 0.5	5.0 \pm ^{0.6} _{0.2}
Declining	Δh	± 2.0	
Paper width	W	18.0 \pm 0.5	
Hole position	W1	9.0 \pm 0.5	
Lead clinch height	H0	16.0 \pm 0.5	
Product height	H1	38.5Max. (35.5Max.)	
Lead length	H	19.5Max.	
Hole diameter	D0	$\phi 4.0 \pm 0.2$	
Paper thickness	t	0.7 \pm 0.2	

- Forming Dimensions

RA-XXXM(S)-V7-F

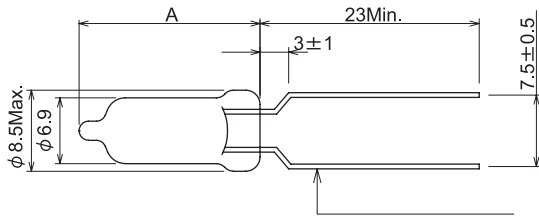

RA-XXXM-V7-F(5)

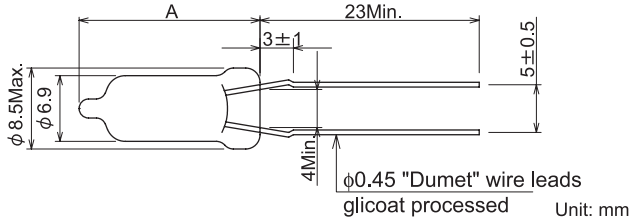

Unit: mm

Accumulative pitch error:

	4 pitch	20 pitch
RA-M(S)-V7-Y	60.0 \pm 0.6	300 \pm 1.5
RA-M(S)-V7-Y(5)	50.8 \pm 0.6	254 \pm 1.5

Marking

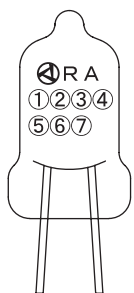

eg)
 Model: RA-272M-V7
 DC spark-over voltage: 2400V
 Tolerance: $\pm 20\% \rightarrow O$
 Calendar: 2004 \rightarrow 4
 Manufactured month: January \rightarrow A

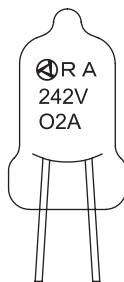

- ①②③.....DC Spark-over Voltage ①② \times 10^③
- ④.....V (Radial)
- ⑤.....Tolerance

Tolerance	$\pm 20\%$	⁺³⁰ / ₋₁₀ %	Other
Symbol	O	R	-

⑥.....Last digit of the calendar year eg.) 2004 \rightarrow 4

⑦.....The month manufactured (see below)

Month	1	2	3	4	5	6	7	8	9	10	11	12
Symbol	A	B	D	E	F	G	H	J	K	L	M	N

RA-XXXM(S)-V7-Y

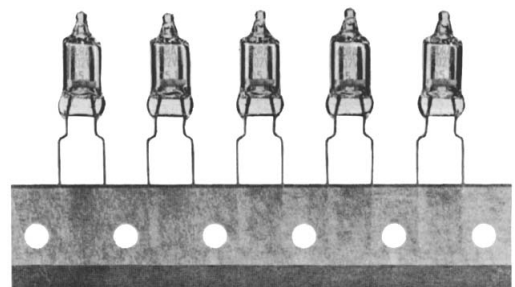

RA-XXXM(S)-V7-Y(5)

