



OKAYA Electric America, Inc.

SPECIFICATIONS

SAMPLE CODE

MASS PRODUCTION CODE

RV640480T-5X7WP-A5

DRAWING NO.

Customer Approved

Date:

Sales Sign	QC Confirmed	Checked By	Designer

Approval For Specifications Only.

* This specification is subject to change without notice.

Approval For Specifications and Sample.



Phone: 219-477-4488
Fax: 219-477-4856
www.okaya.com



OKAYA ELECTRIC AMERICA
52 Marks Road, Suite 1
Valparaiso, Indiana 46383



MODEL NO.

RV640480T-5X7WP-A5

SPEC SAMPLE

1. Table of Contents

No.	Contents	
1	Table of Contents	
2	Record of Revisions	
4	Application	
5	Features	
6	General Specifications	
7	Absolute Maximum Ratings	
8	Electrical Characteristics	
9	Block Diagram	
10	Input / Output Terminals Pin Assignment	
11	Interface Timing	
12	Optical Characteristics	
13	Reliability Test	
14	Packaging	
15	Precautions	
16	Outline Drawing	
18	Incoming Inspection Standards	

**MODEL NO.**

RV640480T-5X7WP-A5

SPEC SAMPLE

4. Application

This specification is applied to the 5.7 inch VGA supported TFT-LCD module, and can display true 262,144 colors(6 bit/ color). The module is designed for OA, Car TV application and other electronic products which require flat panel display of digital signal interface. This module is composed of a 5.7" TFT-LCD panel, a driver circuit and LED backlight unit and used as the input devices for general electric appliances via both finger and pen-entry.

5. Features

- VGA (640×480 pixels) resolution.
- Digital 18 bit parallel RGB.
- Dot inversion mode with stripe type.
- Transparent Touch panel
 - 4-Wire
 - Analog Resistive

6. General Specifications

Item	Specifications	Unit
Screen Size	5.7 (Diagonal)	inch
Display Format	640RGB(H)×480(V)	dot
Active Area	115.2(H)×86.4(V)	mm
Dot Size	0.060(H)×0.180(V)	mm
Pixel Configuration	RGB Vertical Stripe	-
Display Mode	TN Type Transmissive Mode Normally White	-
Surface Treatment	Anti-Glare	-
Viewing Direction	6 O'clock (The Gray Inversion will appear at this direction)	-
Outline Dimension	144.0(W)×104.6(H)×14.5(D)	mm
Weight	(255)	g

**MODEL NO.**

RV640480T-5X7WP-A5

SPEC SAMPLE

7. Absolute Maximum Ratings**7.1 Absolute Ratings of Environment**

Item	Symbol	Value		Unit	Note
		Min.	Max.		
Storage Temperature	T _{ST}	-30	+80	°C	(1)
Operating Ambient Temperature	T _{OP}	-20	+70	°C	(1)

Note (1) Temperature and relative humidity range are shown in the figure below.

(a) 90%RH Max. ($T_a \leq 40^\circ\text{C}$).

(b) Wet-bulb temperature should be 39°C Max. ($T_a > 40^\circ\text{C}$).

(c) No condensation.

7.2 Electrical Absolute Ratings**7.2.1 TFT-LCD Module**

($T_a = 25 \pm 2^\circ\text{C}$, GND=VSS=0V)

Item	Symbol	Value		Unit	Note
		Min.	Max.		
Digital Power Supply Voltage	VCC	-0.3	4.3	V	-

7.2.2 Backlight Unit

($T_a = 25 \pm 2^\circ\text{C}$)

Item	Symbol	Value		Unit	Note
		Min.	Max.		
Current of Backlight Unit	I _B	-	175	mA	(1)
Reverse voltage	V _R	-	15	V	(1)

Note (1) Permanent damage to the device may occur if maximum values are exceeded or reverse voltage is loaded.

8. Electrical Characteristics

8.1 TFT-LCD Module

(Ta=25±2°C)

Item	Symbol	Value			Unit	Note
		Min.	Typ.	Max.		
Power Supply Voltage	VCC	3.0	3.3	3.6	V	-
Input High Threshold Voltage	VIH	0.7VCC	-	VCC	V	-
Input Low Threshold Voltage	VIL	0	-	0.3VCC	V	-
Power Consumption	P _L	-	(0.86)	-	W	(1)
Frame Frequency	F _V	-	60	-	Hz	-
Dot Clock	DCLK	-	25.175	-	MHz	-

Note (1) The specified power consumption is under the conditions at VCC=3.3V, F_V=60Hz, whereas a power dissipation check pattern below is displayed.

Black Pattern / 0 Gray

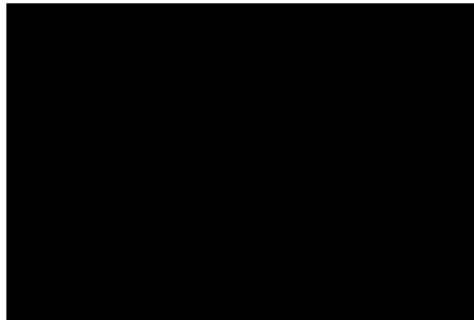

Active Area

8.2 Backlight Unit

(Ta=25±2°C)

Item	Symbol	Value			Unit	Note
		Min.	Typ.	Max.		
Current of Backlight Unit	I _B	-	140	-	mA	-
Voltage of Backlight Unit	V _B	-	9.9	-	V	I _B =140mA
Power Consumption	P _{BL}	-	(1.39)	-	W	I _B =140mA
LED Life Time(25°C)	-	40000	50000	--	hr	(1)

Note (1) : LED life time is defined as under 25±2°C , when the average brightness decrease to 50% of original brightness

8.3 Transparent Touch panel

Electrical characteristics

Item		Value			Unit	Note
		Min.	Typ.	Max.		
Operating Voltage		-	5	7	V	-
Terminal Resistance	X-direction	270	470	600	Ω	At connector
	Y-direction	240	310	500	Ω	At connector
Insulation Resistance		$\geq 20M\Omega$				At DC25V
Linearity		$\leq 1.5\%$				(1)
Chatting		≤ 10 ms				At connector

Note(1): How to measure the linearity

Definition of linearity :

In Fig. 1, when the DC 5V is applied to the "X" directional electrode and "Y" directional electrode of panel alternately, the voltage between the depressed point and the reference surface shall be the output voltage in X and Y surface (E_{ox} and E_{oy}). As shown in Fig. 2, measure the point on 10mm grid enclosed by the positions "A" and "B", which are located at the inside of visible area the specified distance away from the edge, has been depressed.

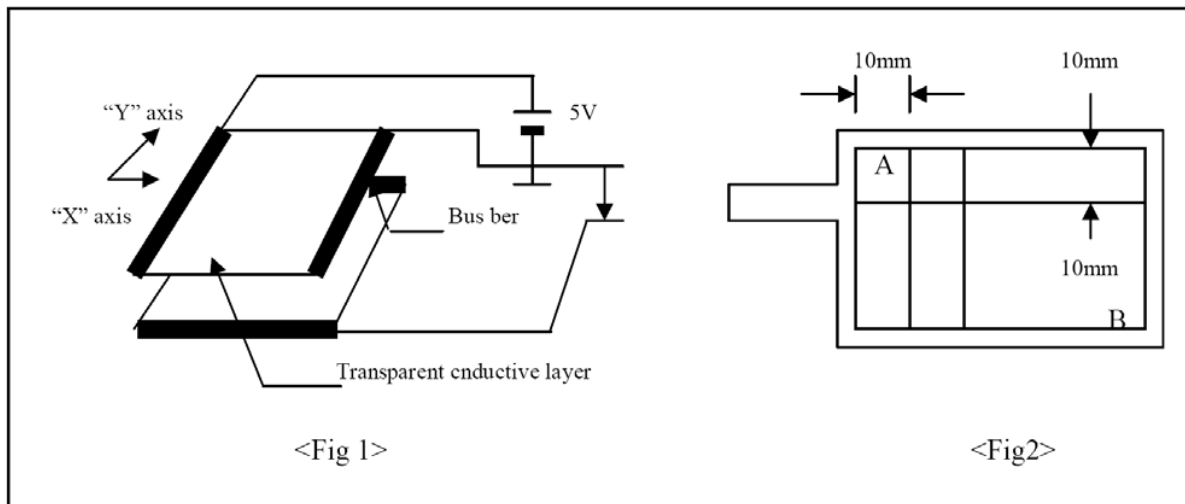

When the output voltage corresponding to every measurement position is plotted as shown in Fig. 3, the difference between the voltage enclosed by the positions "A" and "B" and the output voltage at the same position shall be " ΔE_x " (or " ΔE_y ") and the electric potential difference E_{AB} in X surface, " E_{ABx} " (or E_{AB} in Y surface, " E_{ABy} ") between "A" and "B" shall be defined as the linearity.

Linearity of transparent table (X) = $(\Delta E_x / E_{ABx}) \times 100\%$
 Linearity of transparent table (Y) = $(\Delta E_y / E_{ABy}) \times 100\%$

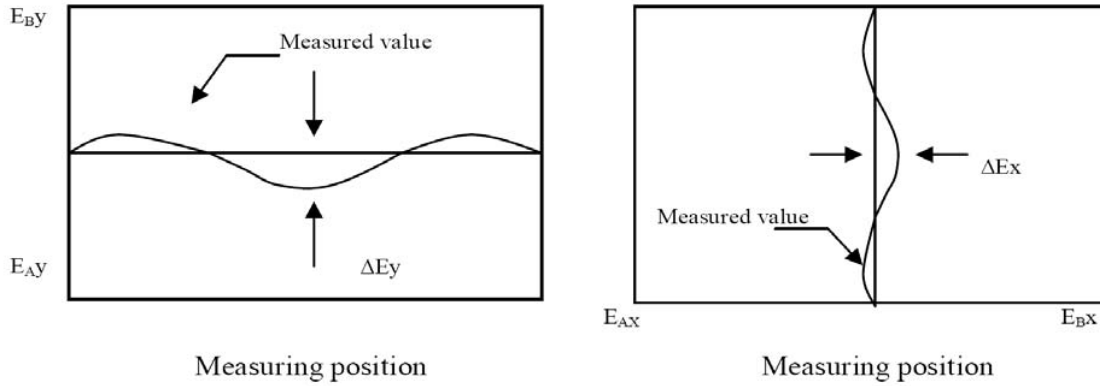

<Fig 3>

Measurement of linearity

A measured value shall be a maximum value in absolute value tolerance when every nodal point on a grid shown in Fig. 5 has been pressed under wiring conditions described in Fig. 4.

<Hitting conditions>

Load : 70 ~ 100g with R0.8 mm polyacetal stylus pen

Measuring area : 1.0mm inside the edge of touch panel active area

<Measuring circuit>

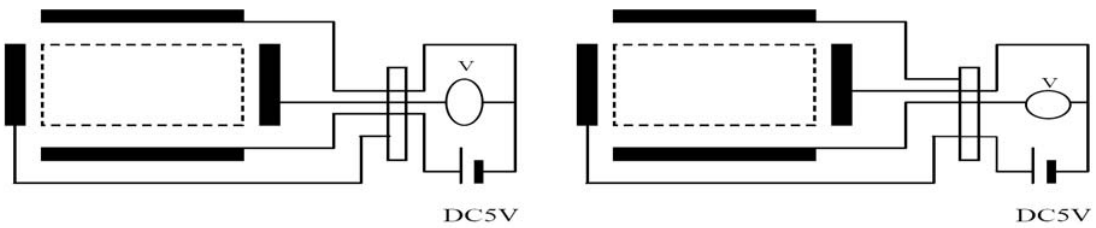

<Fig 4>

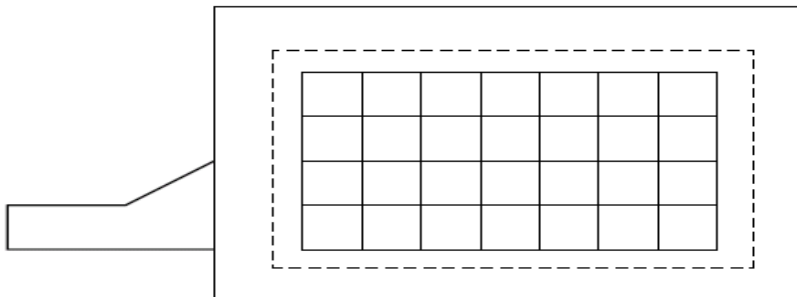

<Fig 5>

9. Block Diagram

9.1 TFT-LCD Module with Backlight Unit

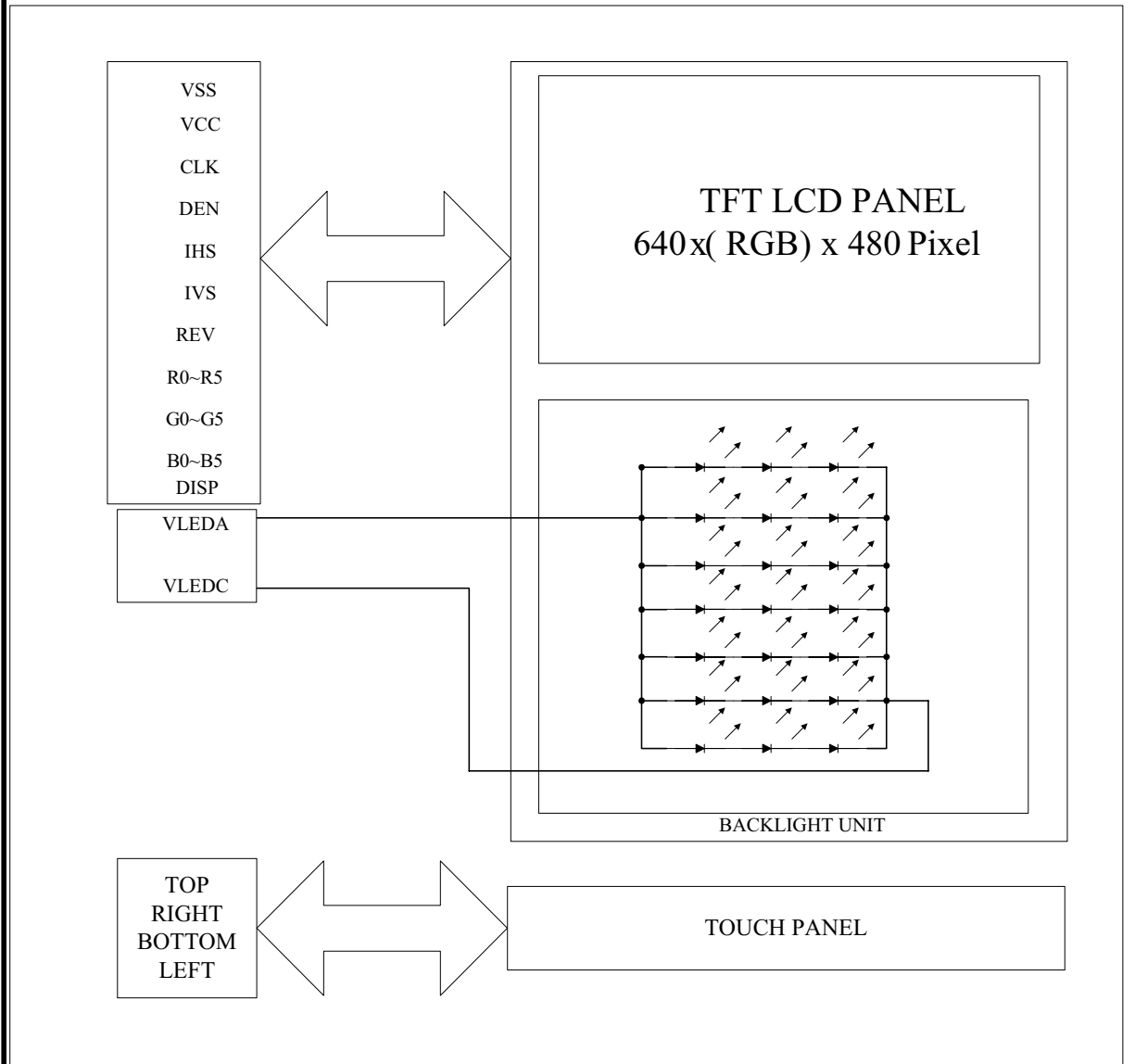

**MODEL NO.**

RV640480T-5X7WP-A5

SPEC SAMPLE

10. Input / Output Terminals Pin Assignment**10.1 TFT-LCD Module**

Connector: CVILUX CF25331D0R0-05

Pin No.	Symbol	I/O	Description
1	VSS	I	Ground
2	CLK	I	Clock signal
3	IHS	I	Horizontal synchronous signal
4	IVS	I	Vertical synchronous signal
5	VSS	I	Ground
6	R0	I	RED data (LSB)
7	R1	I	RED data
8	R2	I	RED data
9	R3	I	RED data
10	R4	I	RED data
11	R5	I	RED data(MSB)
12	VSS	I	Ground
13	G0	I	GREEN data(LSB)
14	G1	I	GREEN data
15	G2	I	GREEN data
16	G3	I	GREEN data
17	G4	I	GREEN data
18	G5	I	GREEN data(MSB)
19	VSS	I	Ground
20	B0	I	Blue data(LSB)
21	B1	I	Blue data
22	B2	I	Blue data
23	B3	I	Blue data
24	B4	I	Blue data
25	B5	I	Blue data(MSB)
26	VSS	I	Ground
27	DEN	I	Input data enable control
28	VCC	I	+3.3V power supply
29	VCC	I	+3.3V power supply

**MODEL NO.**

RV640480T-5X7WP-A5

SPEC SAMPLE

Pin No.	Symbol	I/O	Description
30	REV	I	Selection signal for horizontal/ vertical scanning direction. Note (1)
31	VSS	I	Ground
32	NC	I	No connection
33	VSS	I	Ground

Note (1)

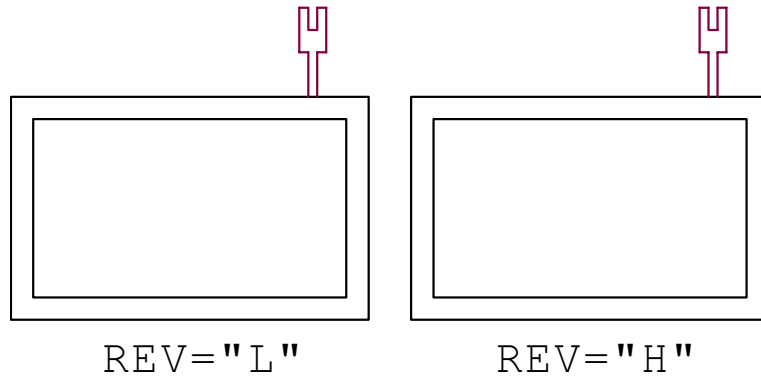
**10.2 Backlight Unit**

Connector: JST BHSR-02VS-1(N)

Pin No.	Symbol	I/O	Description	Wire Color
1	VLEDA	I	Backlight LED Anode.	Red
2	VLEDC	I	Backlight LED Cathode.	Black

10.3 Transparent Touch Panel

Connector: CVILUX CF25041D0R0-10

Pin No.	Symbol
1	TOP
2	RIGHT
3	BOTTOM
4	LEFT



MODEL NO.

RV640480T-5X7WP-A5

SPEC SAMPLE

10.4 Color Data Input Assignment

The brightness of each primary color(red, green and blue) is based on the 6 bit gray scale data input for the color. The higher the binary input, the brighter the color. The table provides the assignment of color versus data input.

Color		Data Signal																	
		Red						Green				Blue							
		D05	D04	D03	D02	D01	D00	D15	D14	D13	D12	D11	D10	D25	D24	D23	D22	D21	D20
Basic Colors	Black	0	0	0	0	0	0	0	0	0	0	0	0	0	0	0	0	0	0
	Red	1	1	1	1	1	1	0	0	0	0	0	0	0	0	0	0	0	0
	Green	0	0	0	0	0	0	1	1	1	1	1	1	0	0	0	0	0	0
	Blue	0	0	0	0	0	0	0	0	0	0	0	0	1	1	1	1	1	1
	Cyan	0	0	0	0	0	0	1	1	1	1	1	1	1	1	1	1	1	1
	Magenta	1	1	1	1	1	1	0	0	0	0	0	0	0	1	1	1	1	1
	Yellow	1	1	1	1	1	1	1	1	1	1	1	1	0	0	0	0	0	0
	White	1	1	1	1	1	1	1	1	1	1	1	1	1	1	1	1	1	1
Gray Scale Of RED	Red(0) / Dark	0	0	0	0	0	0	0	0	0	0	0	0	0	0	0	0	0	0
	Red(1)	0	0	0	0	0	1	0	0	0	0	0	0	0	0	0	0	0	0
	Red(2)	0	0	0	0	1	0	0	0	0	0	0	0	0	0	0	0	0	0
	:	:	:	:	:	:	:	:	:	:	:	:	:	:	:	:	:	:	:
	:	:	:	:	:	:	:	:	:	:	:	:	:	:	:	:	:	:	:
	Red(61)	1	1	1	1	0	1	0	0	0	0	0	0	0	0	0	0	0	0
	Red(62)	1	1	1	1	1	0	0	0	0	0	0	0	0	0	0	0	0	0
Red(63)	1	1	1	1	1	1	0	0	0	0	0	0	0	0	0	0	0	0	
Gray Scale Of Green	Green(0) / Dark	0	0	0	0	0	0	0	0	0	0	0	0	0	0	0	0	0	0
	Green(1)	0	0	0	0	0	0	0	0	0	0	1	0	0	0	0	0	0	
	Green(2)	0	0	0	0	0	0	0	0	0	0	1	0	0	0	0	0	0	
	:	:	:	:	:	:	:	:	:	:	:	:	:	:	:	:	:	:	
	:	:	:	:	:	:	:	:	:	:	:	:	:	:	:	:	:	:	
	Green(61)	0	0	0	0	0	0	1	1	1	1	0	1	0	0	0	0	0	
	Green(62)	0	0	0	0	0	0	1	1	1	1	1	0	0	0	0	0	0	
Green(63)	0	0	0	0	0	0	1	1	1	1	1	1	0	0	0	0	0		
Gray Scale Of Blue	Blue(0) / Dark	0	0	0	0	0	0	0	0	0	0	0	0	0	0	0	0	0	0
	Blue(1)	0	0	0	0	0	0	0	0	0	0	0	0	0	0	0	0	0	1
	Blue(2)	0	0	0	0	0	0	0	0	0	0	0	0	0	0	0	0	1	0
	:	:	:	:	:	:	:	:	:	:	:	:	:	:	:	:	:	:	:
	:	:	:	:	:	:	:	:	:	:	:	:	:	:	:	:	:	:	:
	Blue(61)	0	0	0	0	0	0	0	0	0	0	0	0	1	1	1	1	0	1
	Blue(62)	0	0	0	0	0	0	0	0	0	0	0	0	1	1	1	1	1	0
Blue(63)	0	0	0	0	0	0	0	0	0	0	0	0	1	1	1	1	1	1	

**MODEL NO.**

RV640480T-5X7WP-A5

SPEC SAMPLE

11. Interface Timing**11.1 Input Signal Characteristics**

PARAMETER	Symbol	Min.	Typ.	Max.	Unit
HS setup time	T_{hst}	10	-	-	ns
HS hold time	T_{hhd}	10	-	-	ns
VS setup time	T_{vst}	10	-	-	ns
VS hold time	T_{vhd}	10	-	-	ns
Data setup time	T_{dsu}	10	-	-	ns
Data hold time	T_{dhd}	10	-	-	ns
DEN setup time	T_{esu}	10	-	-	ns
VS falling to HS falling time on odd field @ RGB mode	T_{HV_O}	-4	0	+4	T_{CPH}
VS falling to HS falling time on even field @ RGB mode	T_{HV_E}	0.4	0.5	0.6	T_H

PARAMETER	Symbol	Min.	Typ.	Max.	Unit
CLK frequency	F_{CPH}	-	25.175	-	MHz
CLK period	T_{CPH}	-	39.7	-	ns
CLK pulse duty	T_{CWH}	40	50	60	%
HS period	T_H	-	800	-	T_{CPH}
HS pulse width	T_{WH}	5	30	-	T_{CPH}
HS-DEN time	T_{HS}	112	144	175	T_{CPH}
DEN pulse width	T_{EP}	-	640	-	T_{CPH}
VS pulse width	T_{WV}	1	3	5	T_H
VS-DEN time	T_{STV}	-	35	-	T_H
VS period	T_V	-	525	-	T_H

Note: When SYNC mode is used, 1st data start from 144th CLK after HS falling (when $STHD[5:0]=00000$)



MODEL NO.

RV640480T-5X7WP-A5

SPEC SAMPLE

11.2 Waveform

11.2.1 Clock and Data input waveforms

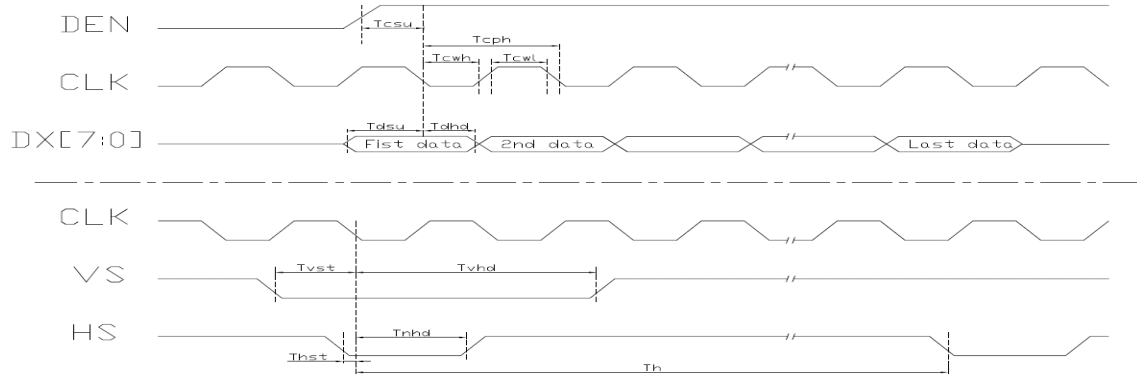

11.2.2 Data input format for RGB Mode

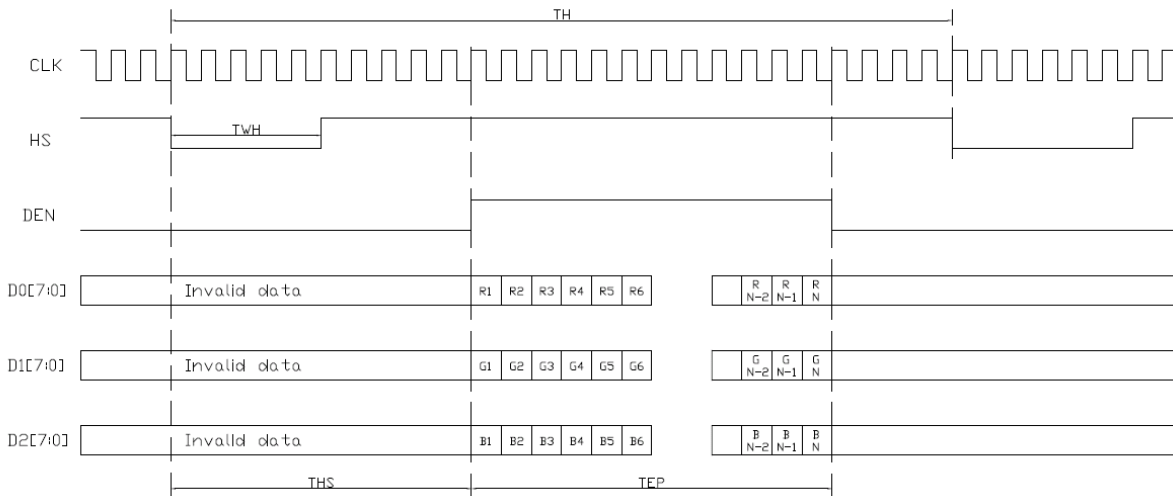

11.2.3 The HS & VS timing of the ODD/EVEN field.

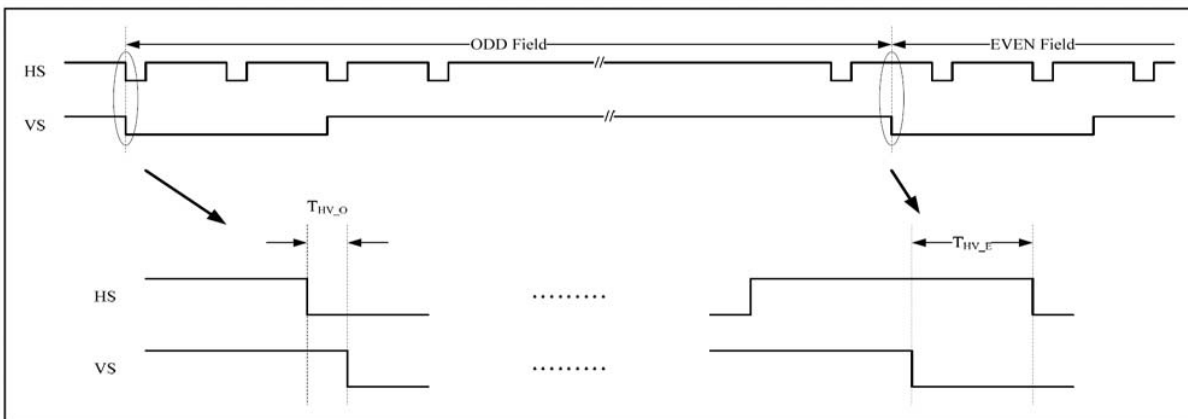



MODEL NO.

RV640480T-5X7WP-A5

SPEC SAMPLE

12. Optical Characteristics

The optical characteristics should be measured in a dark environment (≤ 1 lux) or equivalent state with the methods shown in Note (4).

Item	Symbol	Conditions	Min.	Typ.	Max.	Unit	Note	
Contrast Ratio	CR	$\theta_x=0^\circ, \theta_y=0^\circ$ Viewing Normal Angle	200	(400)	-	-	(2)	
Response Time	T_R		-	15	-	ms	(3)	
	T_F		-	35	-	ms		
Luminance(Center)	Y		250	(290)	-	cd/m ²	(4)	
Brightness uniformity	BUNI		80	(85)	-	%	(5)	
Color Chromaticity	Red		Rx	(0.565)	(0.615)	(0.665)	-	(1),(4)
			Ry	(0.302)	(0.352)	(0.402)	-	
	Green		Gx	(0.281)	(0.331)	(0.381)	-	
			Gy	(0.520)	(0.570)	(0.620)	-	
	Blue		Bx	(0.093)	(0.143)	(0.193)	-	
		By	(0.066)	(0.116)	(0.166)	-		
	White	Wx	(0.279)	(0.329)	(0.379)	-		
		Wy	(0.315)	(0.365)	(0.415)	-		
Viewing Angle	Horizontal	θ_{x+}	(55)	(65)	-	deg.		
		θ_{x-}	(55)	(65)	-			
	Vertical	θ_{y+}	(55)	(60)	-			
		θ_{y-}	(55)	(70)	-			

Note (1) Definition of Viewing Angle (θ_x, θ_y):

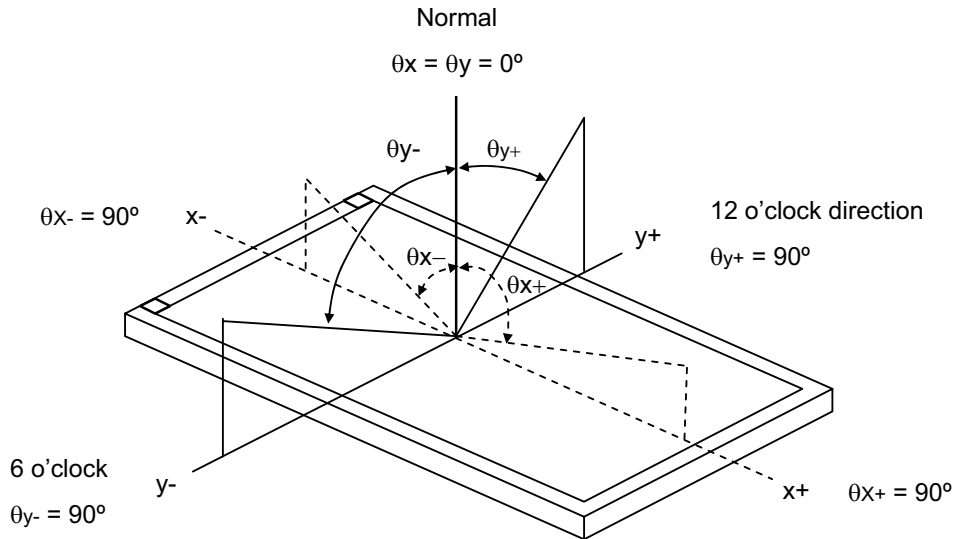

Note (2) Definition of Contrast Ratio (CR):

Measured at the center point of panel

$$\text{Contrast Ratio (CR)} = L_{255} / L_0$$

L255: Luminance of gray level 255

L 0: Luminance of gray level 0.

Note (3) Definition of Response Time (T_R, T_F):

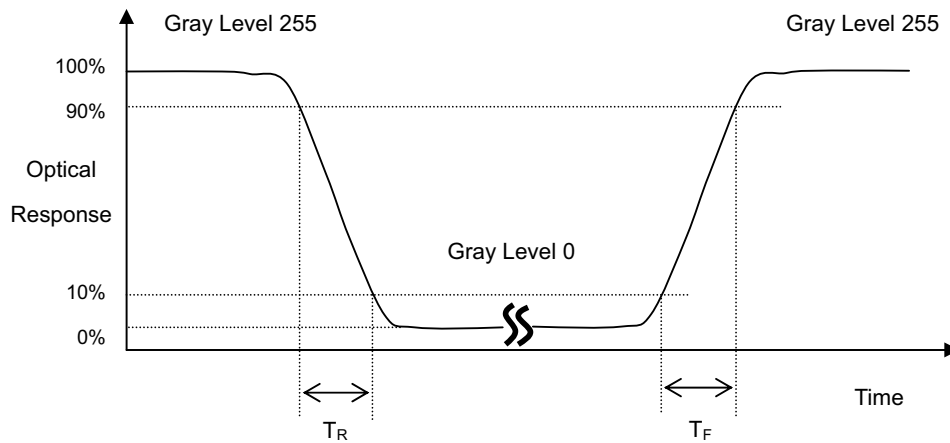

Note (4) Measurement Set-Up:

The LCD module should be stabilized at a given temperature for 30 minutes to avoid abrupt temperature change during measuring. In order to stabilize the luminance, the measurement should be executed after lighting Backlight for 30 minutes in a windless room.

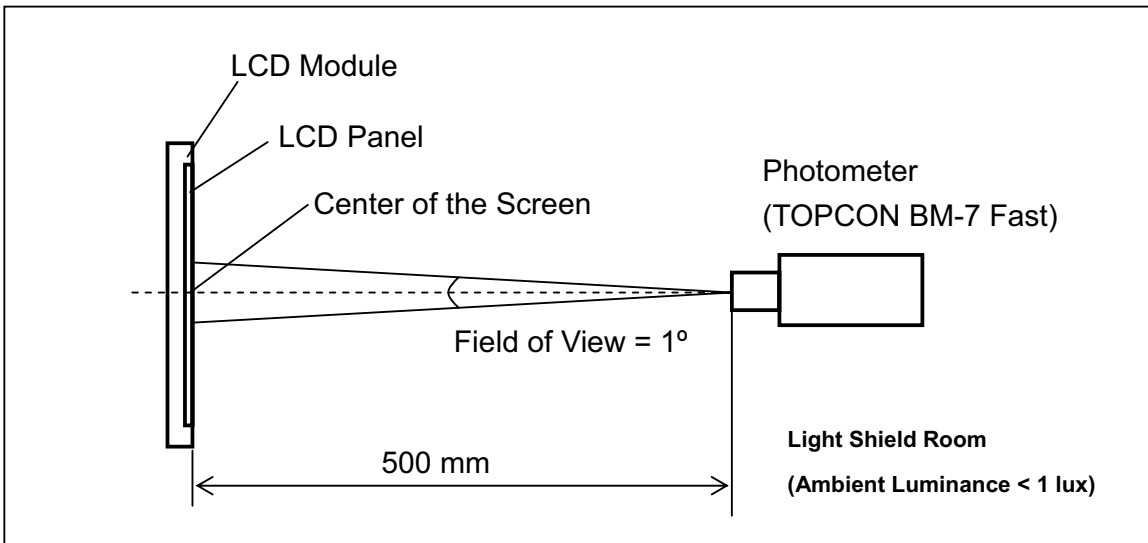

Note (5) Definition of brightness uniformity

Brightness uniformity=(Min Luminance of 9 points)/(Max Luminance of 9 points)×100%

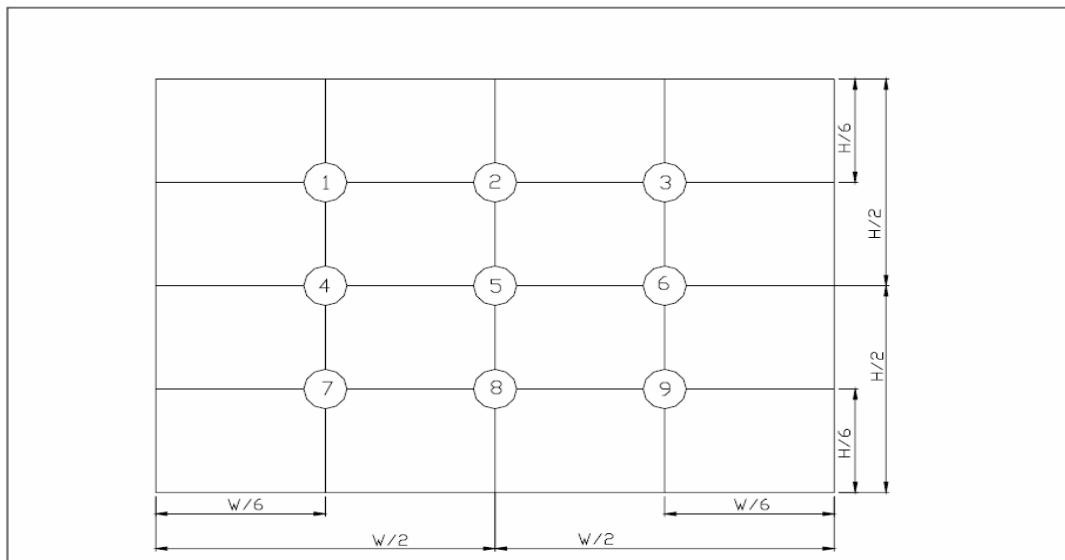

(單位 : mm)

**MODEL NO.**

RV640480T-5X7WP-A5

SPEC SAMPLE

13. Reliability Test

No.	Test Items	Test Condition	Remark
1	High Temperature Storage Test	T _a = 80°C 240 hours	-
2	Low Temperature Storage Test	T _a = -30°C 240 hours	-
3	High Temperature Operation Test	T _a = 70°C 240 hours	-
4	Low Temperature Operation Test	T _a = -20°C 240 hours	-
5	High Temperature and High Humidity Operation Test	T _a =60°C 90%RH 240 hours	-
6	Electro Static Discharge Test (non-operating)	-Panel Surface/Top Case : 150pF, 330Ω Air: ±15kV, Contact: ±8kV	-
7	Mechanical Shock Test (non-operating)	Half sine wave, 80G, 11ms 3 times shock of each six surfaces	-
8	Vibration Test (non-operating)	Sine wave, 10 ~ 55 ~ 10Hz, 3 axis, 2 hours/axis	-
9	Thermal Shock Test (non-operating)	-20°C (30min) ~ 70°C (30min), 100 cycles	-
10	Drop Test(with Carton)	Height: 80cm 1 corner, 3 edges, 6 surfaces	-

14. Packaging

Packing Method

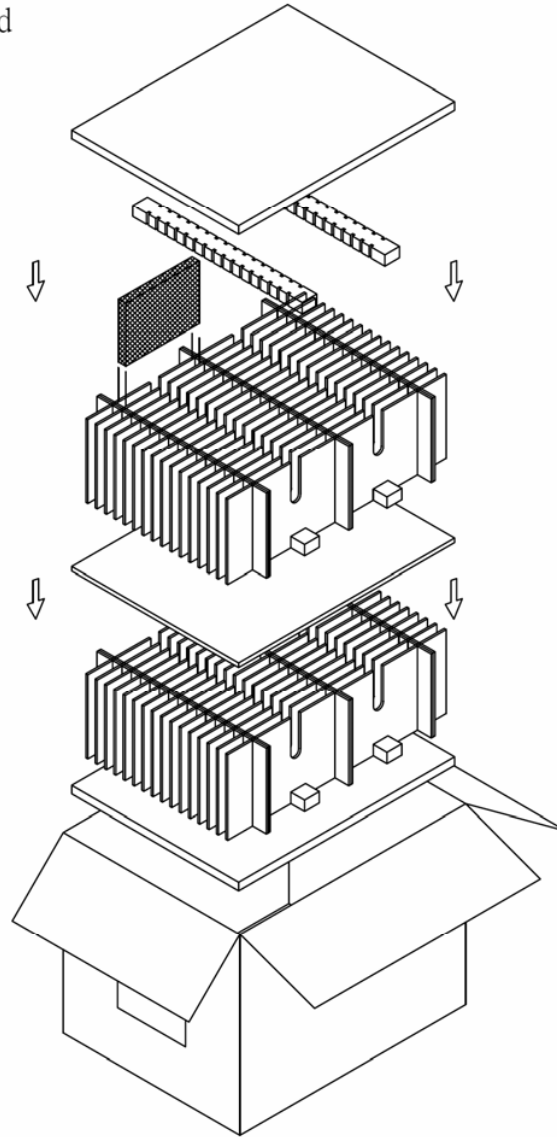

PARTS LIST					
	ITEM	SIZE(LxWxH) unit:mm	MATERIAL	Q.T.Y	NOTE
1	STATIC SHIEDING BAGS	200.0x145.0*0.09		60	
2	PU FOAM	440.0x340.0x15.0	SPONGE	2	
3	EPE PAD	345.0x30.0x20.0		8	
4	CARD BOARD	345.0x150.0x3.5	CARTON	12	
5	CARD BOARD	450.0x150.0x3.5	CARTON	32	
6	CARD BOARD	440.0x340.0x8.0	CARTON	1	
7	EXTERNAL BOX	460.0x360.0x355.0	CARTON	1	
8	PRODUCT	144.0x104.6x14.5		60	



MODEL NO.

RV640480T-5X7WP-A5

SPEC SAMPLE

15. Precautions

15.1 Assembly and Handling Precautions

- (1) Do not apply rough force such as bending or twisting to the module during assembly.
- (2) It's recommended to assemble or to install a module into the user's system in clean working areas. The dust and oil may cause electrical short or worsen the polarizer.
- (3) Don't apply pressure or impulse to the module to prevent the damage of LCD panel and Backlight.
- (4) Always follow the correct power-on sequence when the LCD module is turned on. This can prevent the damage and latch-up of the CMOS LSI chips.
- (5) Do not plug in or pull out the I/F connector while the module is in operation.
- (6) Do not disassemble the module.
- (7) Use a soft dry cloth without chemicals for cleaning, because the surface of polarizer is very soft and easily scratched.
- (8) Moisture can easily penetrate into LCD module and may cause the damage during operation.
- (9) High temperature or humidity may deteriorate the performance of LCD module. Please store LCD module in the specified storage conditions.
- (10) When ambient temperature is lower than 10°C, the display quality might be reduced. For example, the response time will become slow.

15.2 Safety Precautions

- (1) If the liquid crystal material leaks from the panel, it should be kept away from the eyes or mouth. In case of contact with hands, skin or clothes, it has to be washed away thoroughly with soap.
- (2) After the module's end of life, it is not harmful in case of normal operation and storage.

15.3 Cautions for installing and assembling

Bezel edge must be positioned in the area between the Active area and View area.

The bezel may press the touch screen and cause activation if the edge touches the active area. A gap of approximately 0.5mm is needed between the bezel and the top electrode.

It may cause unexpected activation if the gap is too narrow. There is a tolerance of 0.2 to 0.3mm for the outside dimensions of the touch panel and tail. A gap must be made to absorb the tolerance in the case and connector.

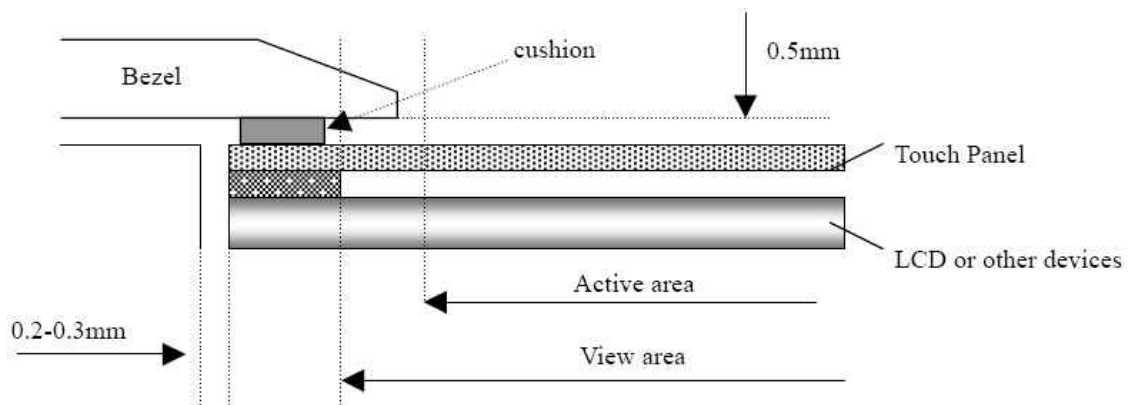



MODEL NO.

RV640480T-5X7WP-A5

SPEC SAMPLE

16. Outline Drawing

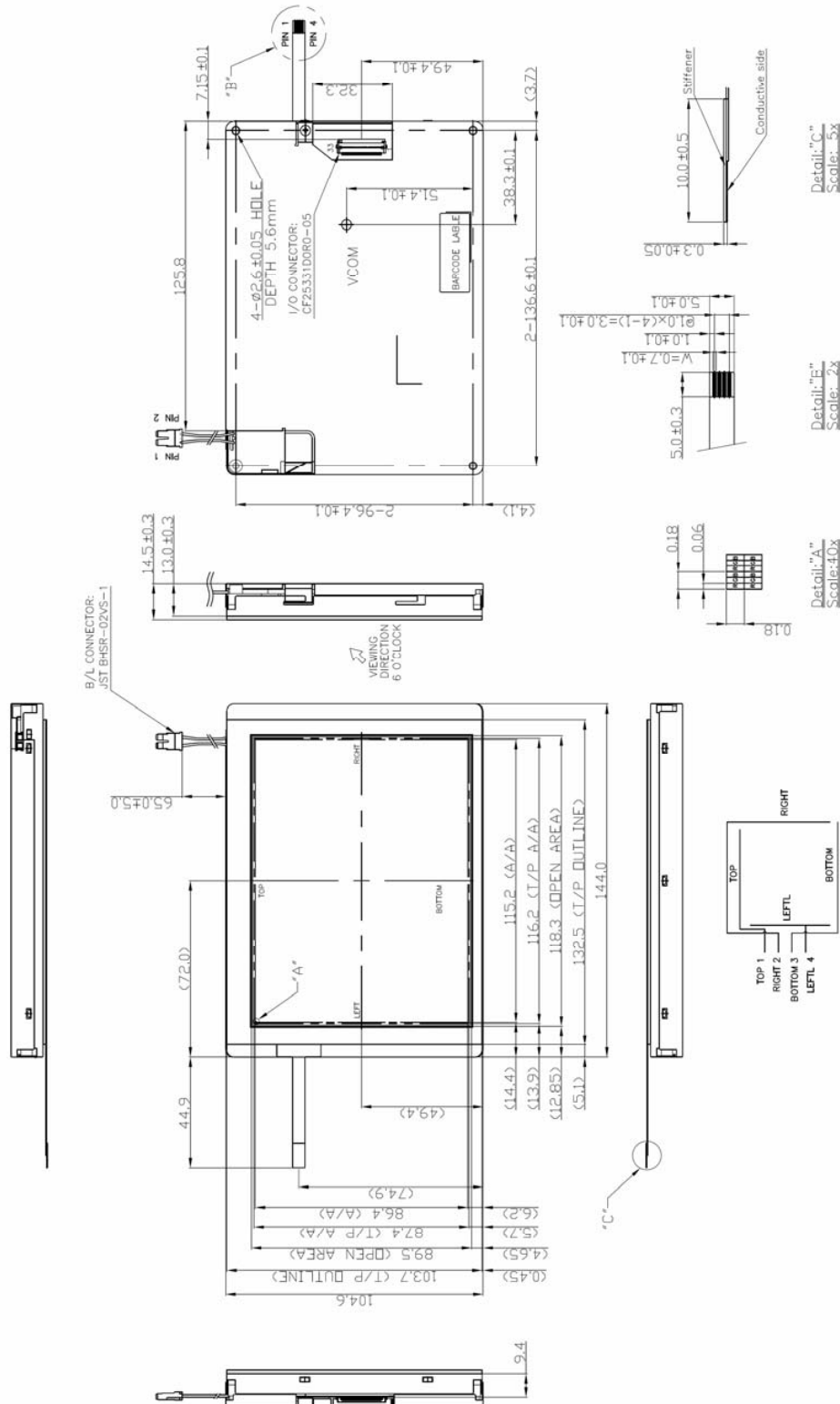

18. Incoming Inspection Standards

18.1 The environmental condition of inspection

The environmental condition and visual inspection shall be conducted as below.

- (1) Ambient temperature $25 \pm 5^{\circ}\text{C}$
- (2) Humidity: $60 \pm 5\% \text{ RH}$
- (3) Viewing distance is approximately 35 ~ 40 cm
- (4) Viewing angle is normal to the LCD panel as Fig_1 (10°)
- (5) Ambient Illumination: 300 ~ 500 Lux for external appearance inspection

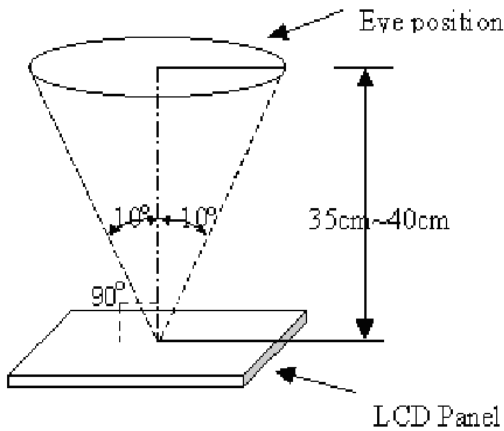

Fig_1

18.2 The defects classify of AQL as following:

Class of defects	AQL	Definition
Major	0.65%	It is defect that is likely to result in failure or to reduce materially the usability of the intended function.
Minor	1.5%	It is a defect that will not result in functioning problem with deviation classified.



MODEL NO.

RV640480T-5X7WP-A5

SPEC SAMPLE

18.3 Inspection Parameters

Item		Specification/Description			Note	
Display	Function	No Display			-	
		Malfunction			-	
Operating	Contrast ratio	Out of Spec			-	
	Line defect	No obvious Vertical and Horizontal line defect in bright , dark and colored.			-	
	Point Defect (red,green,blue,dark)	Item	Acceptable number			Note: 1、2、 5、6、7
			A	B	Total	
		BRIGHT DOT	$N \leq 2$	$N \leq 2$	$N \leq 7$	
		DARK DOT	$N \leq 3$	$N \leq 4$		
		TOTAL DOT	$N \leq 4$	$N \leq 5$		
TWO ADJACENT DOT	NOT ALLOWED					
THREE OR MORE ADJACENT DOT	NOT ALLOWED					
External Inspection (non-operating)	Scratch on the polarizer	L(mm)	W(mm)	Acceptable number	Note:3	
		$L \leq 2.5$	$W \leq 0.1$	4		
		$L > 2.5$	$W > 0.1$	0		
	Dent or bubble on the polarizer	Dimension(mm)		Acceptable number	Note:4	
$D \leq 0.5$		4				
$D \leq 0.15$		Disregard				
Foreign material on the polarizer	Dimension(mm)		Acceptable number	Note:4		
	$D \leq 0.5$		4			
	$D \leq 0.15$		Disregard			

Note1. Distance between point defect distance should be large than 5 mm.

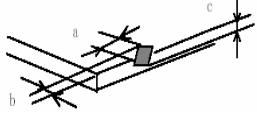
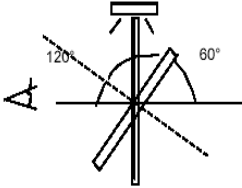
Item	Specification/Description		Note	
Touch Panel	Glass chipping		$a \leq 3\text{mm}$ $b \leq 3\text{mm}$ $c \leq t$ (t : Glass think)	Note:8
	Newton-ring	(In case of doubtful situations) Observe on 60° from the product surface under a while Fluorescent lamp(3-wavelength lamp). 	Average diameter $\leq 7\text{mm}$ N ≤ 1	Note:8

Note2. The definition of dot defect : The dot defect was judged after repair and the size of a defective dot over 1/2 of whole dot is regarded as one defective dot.

Note3.

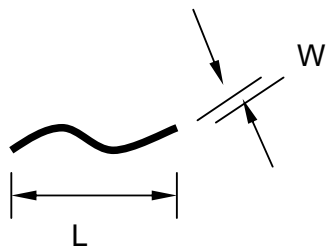

Note4. D : Diameter $D=(a+b)/2$

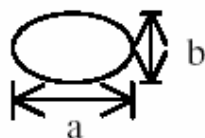

Note5. Bright dot is defined through 6% transmission ND Filter as following.

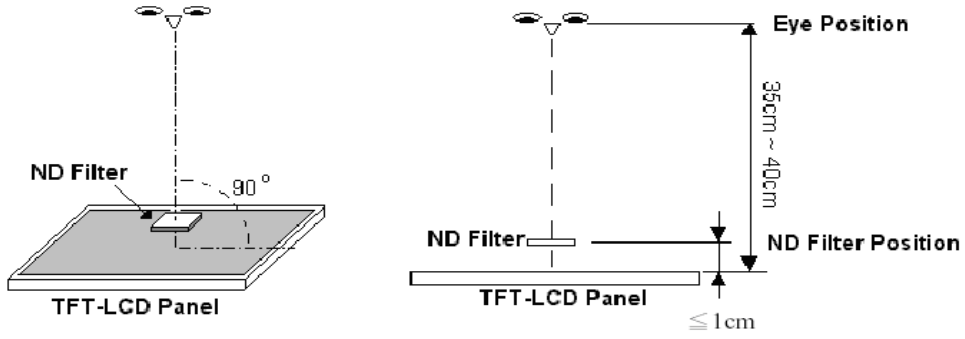

Note6. ADJACENT DOT



Note7.

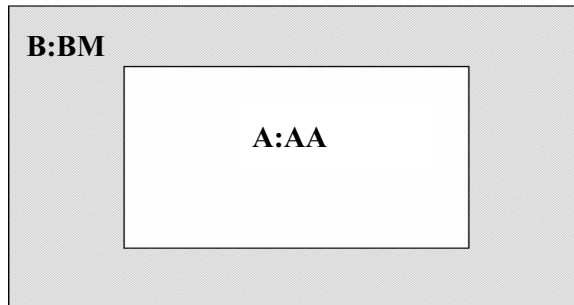

Note8.

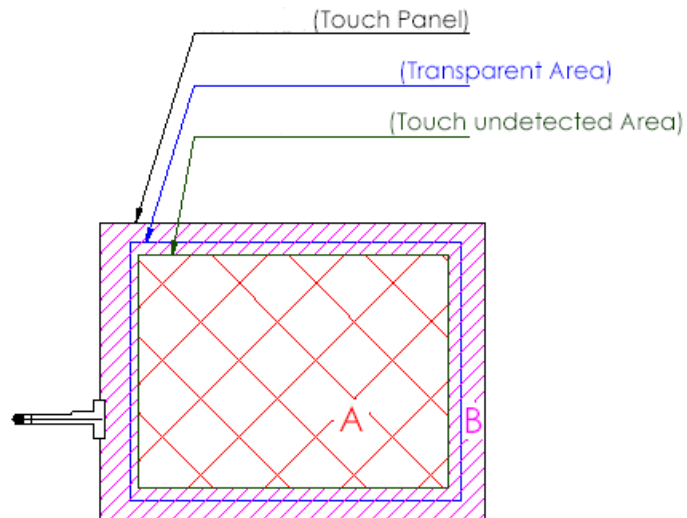

A area : Without any defect point effect on normal operation.

B area : None-specify

18.4 Handling of LCM

- (1) Don't give external shock.
- (2) Don't apply excessive force on the surface.
- (3) Liquid in LCD is hazardous substance. Must not lick and swallow. when the liquid is attach to your hand, skin, cloth etc. Wash it out thoroughly and immediately.
- (4) Don't operate it above the absolute maximum rating.
- (5) Don't disassemble the LCM.