

SURGE ABSORBER

Fax Back Document #1400

The technical data provided by Okaya Electric Industries Co., Ltd. and/or Okaya America, Inc. is designed to assist a potential buyer's engineer in applying these products to electrical, electronic, and electromechanical applications.

The information provided in this catalog, as well as any additional data supplied by Okaya or Okaya representatives, is for general use only to assist the buyer in making its own independent decision as to the suitability of the products for the buyer's intended use and application.

Except for any limited warranties contained in Okaya Electric America, Inc.'s Terms and Conditions, OKAYA DISCLAIMS WITH RESPECT TO THEIR GOODS AND DATA AND INFORMATION RELATED TO THEM, ALL IMPLIED WARRANTIES OF MERCHANTABILITY AND ALL IMPLIED WARRANTIES OF FITNESS FOR A PARTICULAR PURPOSE.

The specifications contained in this catalog are subject to change without notice.

PART NUMBER	RATING	APPLICATION
RAV-L	90V - 1500V	SURGE PROTECTION OF NETWORK LINE
RAV-LD	360V - 620V	
RA-V6-2	200V - 500V	
CAA	6.8 - 68Vdc	TELECOM AND DATA TRANSMISSION PROTECTION
RSM-XRL	5 - 48V	DATA TRANSMISSION PROTECTION
RSP-TEL (-B)	Telephone	TELECOM PROTECTION
RSP-485	RS-485	DATA TRANSMISSION PROTECTION
RA-V7	2400V - 3600V	SURGE PROTECTION OF POWER LINE
RAV-401(782)QWZ	403V, 783V	
RAV-401(781)PWZ	403V, 783V	
RAV-401(781)BWZ-2A(3C)	403V, 783V	
RAV-781BXZ-2A(3C)	783V	SURGE PROTECTION OF 3-PHASE POWER LINE
RAV781BXZ-4	700V	
RAV-781(152)BYZ-2(A)	783V, 1470V	
RAV-401(781)LDEZ	403V, 783V	SURGE PROTECTION OF POWER LINE
RAM-LAS	125, 250VAC	
RAM-BWZ-(4)(5)	125 - 500VAC	SURGE PROTECTION OF 3-PHASE POWER LINE
RAM-BXZ-(4)(5)	250 - 300VAC	

• SURGE

Power surges, both voltage and current, are occurring continually in today's power systems. Whether they occur naturally, such as from lightning and static electricity; or are man made, such as inductive surges from motor, transformers, solenoids, etc. power surges are a fact of life. These power surges have a very high voltage and current level as compared to electrical noise.

Recent developments in electronic designs have tended toward smaller and higher density packaging of circuitry. This results in a greater susceptibility to surges. Once attacked by a surge, electronic circuits can be destroyed in as short as 0.1 μ sec. The designer of electronic equipment must be aware of, and be able to deal with, power surges in product design.

OKAYA's RAV surge absorbers are designed to assist in dealing with the problem of power surges. The RAV series is a unique new approach which combines the features of two well known technologies. Combining the high speed capabilities of Metal Oxide Varistor (MOV) with the large power handling capability of Gas Arrester, OKAYA has developed a product which can clamp power surges faster than gas arrester alone and handle large power surges far beyond the capability of MOV.

• CONSTRUCTION

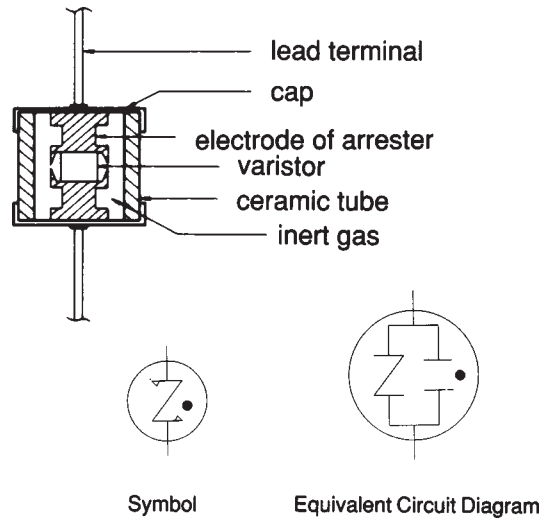

• FEATURES

The RAV Surge Absorber is applicable for the protection of many types of electrical equipment. The RAV has the following features:

- 1) Large capacity surge protection
- 2) Fast response time
- 3) Good endurance to repetitive lightning
- 4) High clipping performance
- 5) Low internal capacitance
- 6) No environmentally hazardous materials

• OPERATING PRINCIPAL

The RAV connected between lines will shunt the surge from one side of the line to the other. The high speed varistor quickly shunts the surge until the slower, but more powerful gas arrester takes over. This allows the gas arrester to handle the high energy portion of the surge and protect the MOV from damage. This interaction of the RAV assures safe handling of the power surge and long life stability to the MOV.

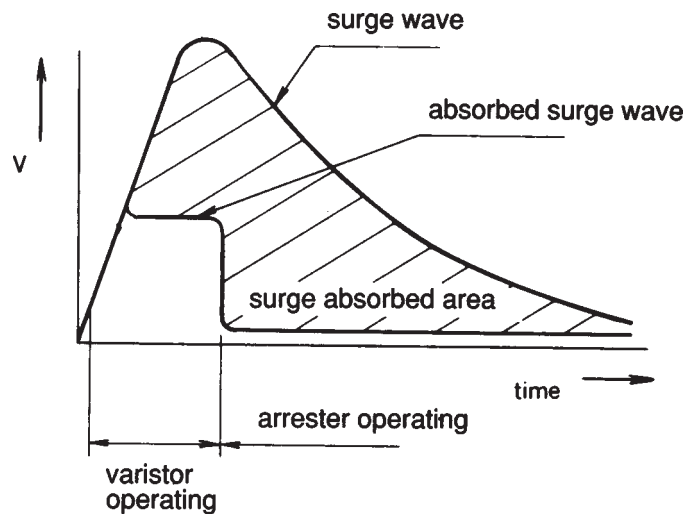

SURGE ABSORBER

• DYNAMIC CHARACTERISTICS

Fig. 1 Shows the dynamic characteristics of Varistor, Gas Arrester & RAV.

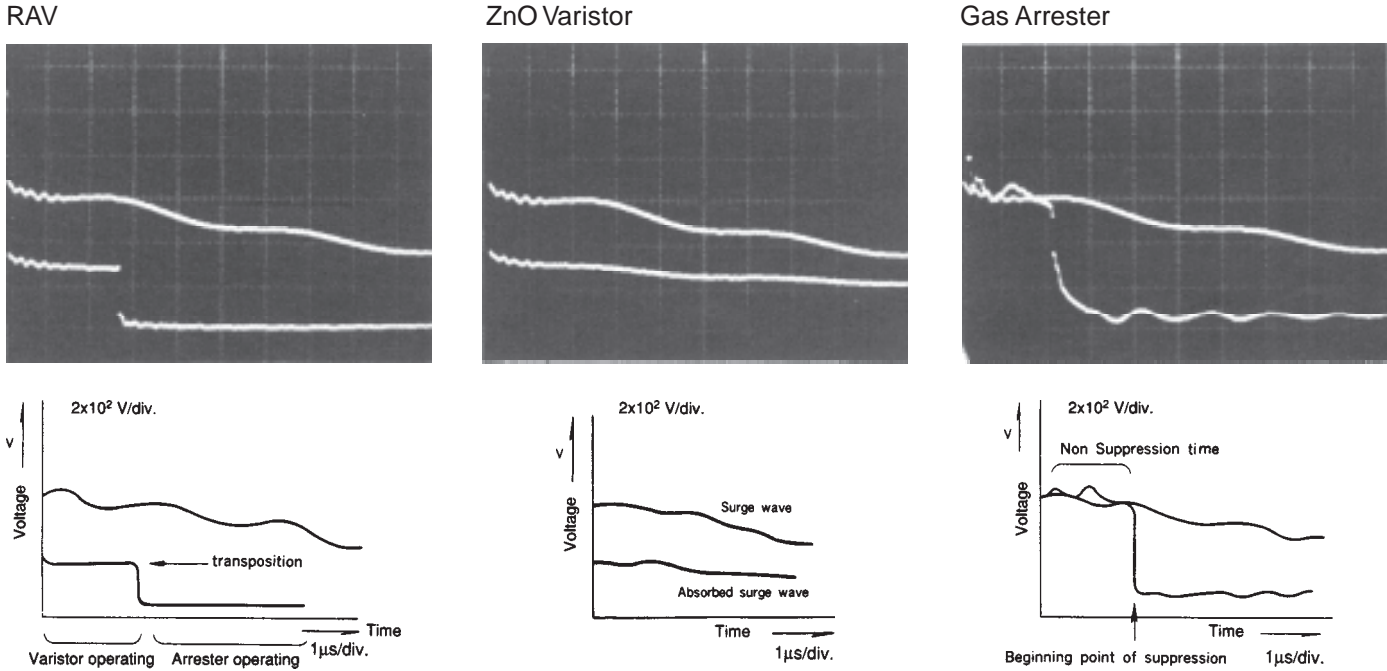

Lightning surges have precipitous dv/dt values and huge electrical charge. Surge absorbers must assimilate this surge. This limiting voltage capability varies depending upon the type of absorber. The voltage and current curves in Fig. 2 characterize varistors and gas arresters.

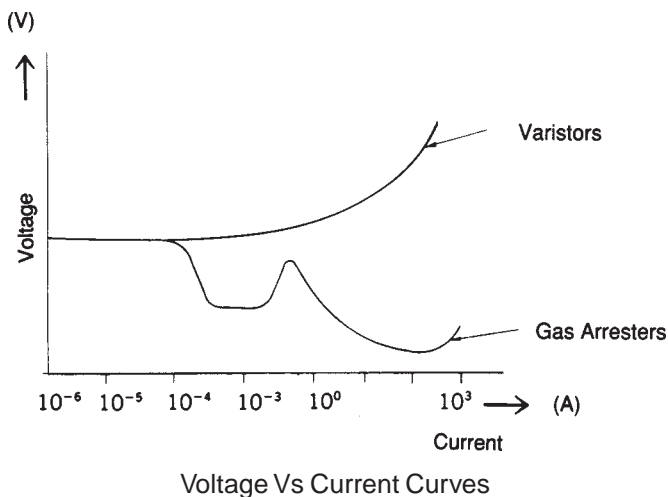

Figure 2

VARISTORS

Varistor voltage is specified by the manufacturer at low current (ie, 0.1-1.0 mA). The clamping voltage of the Varistor at higher current (ie, 1.0 Amp) can be several times higher and will increase as the current goes higher (See Fig. 2). Varistors have a very fast response time (ie, 50 nsec.) and will clamp at rated voltage for low currents or short periods of time. However, as a power surge increases in either current or duration, the Varistor clamping voltage can rise to unsafe levels, ultimately failing when its maximum energy level is exceeded. Although the Varistor may survive most power surges, each time it absorbs a power surge, damage occurs to the Varistor. Ultimately the MOV is rendered inoperative and unable to perform its suppression task.

GAS ARRESTERS

The rated voltage of the Gas Arrester is defined as a DC breakdown Voltage (E_z). In contrast to the Varistor, as the surge current increases this voltage decreases. Therefore, once the Gas Arrester is triggered, the voltage level is maintained at a safe level, regardless of the increase in current or duration of the power surge. Typically the trigger response time is 1 μ sec.

• RAV CHARACTERISTICS

Power surges resulting from indirect lightning strikes occur with precipitous speed. The dv/dt of the rising waveform will exceed $100v/\mu\text{sec}$. As a result, a surge absorber without excellent response performance will be unable to protect equipment from damage. The element performance of gas arresters and other general surge absorbers is evaluated by means of the Voltage-Time characteristic curve, which expresses the relationship between the rise time of the voltage and the firing potential voltage of the device at the time of the surge rise. The accompanying graph shows an example of V-T characteristics.

The electrical characteristics of gas arresters are normally measured by the element performance, expressed in terms of the DC breakdown voltage. When such devices are used as surge absorbers, however, the more important value is the surge firing potential voltage (V_f : the voltage at which surge discharge begins). For example, even in the case of a gas arrester with DC breakdown voltage of 90V, the V_f value at $1kV/\mu\text{s}$ indicates a surge firing potential of about 500V (See Fig. 3). The surge cannot be discharged until the voltage rises to this value. This characteristic forms the chief failing of gas arresters. With the RAV surge absorber, however, the same 90V type permits the discharge operation to begin at a V_f (at $1kV/\mu\text{s}$), of about 210V. As a result, the discharge operation begins at a level 290V lower than the gas arrester.

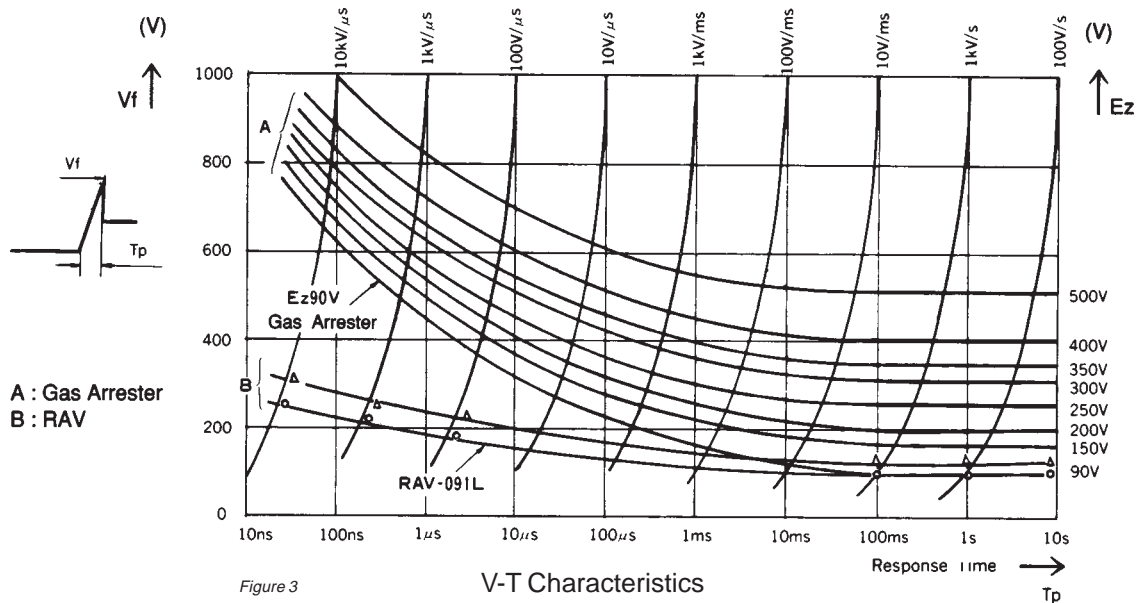

There are two standard tests which are used to classify surge absorbers. Each test uses a signal pulse which is imposed on the device under test (DUT). This pulse is described by two sets of numbers (1.2/50 μsec . and 8/20 μsec .). The first number in each set is the duration of the rise time of the signal imposed on the DUT. The second number is 1/2 of the duration of the fall time of the signal imposed on the DUT.

The 1.2/50 μsec . test is used to determine the peak surge voltage the DUT can withstand. The 8/20 μsec . test is used to determine the maximum discharge current the DUT can withstand. These wave forms are derived from IEEE-587, 1980 (ANSI-62.41). This standard defines the open circuit and short circuit current waveforms which can be expected to occur on AC power lines of 600 Volts (RMS) or less.

SURGE ABSORBER

• BASIC CIRCUIT TO PROTECT EQUIPMENT

Input impedance is high

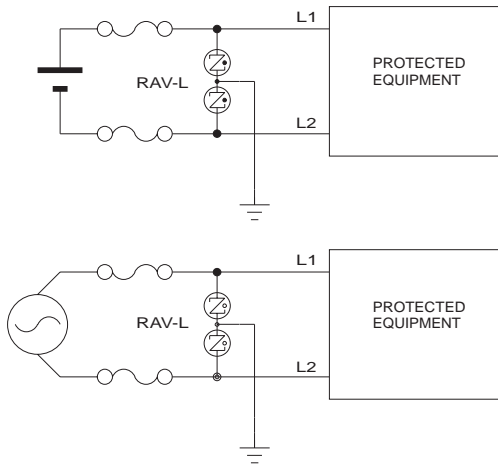

Input impedance is low

The resistors R or MOV Z control continuous flow discharge and low value ones should be selected so as not to reduce the capacity of the surge protection device.

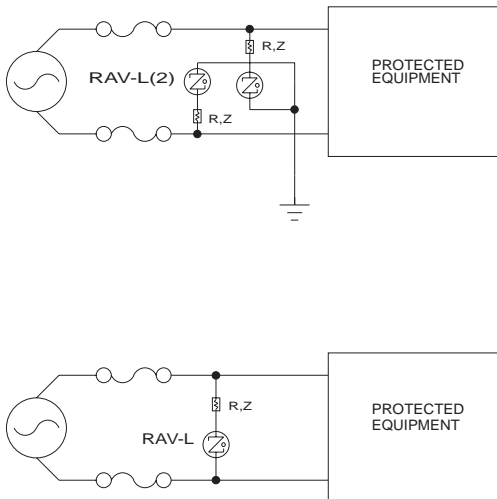

• APPLICATION

Protecting telephone lines

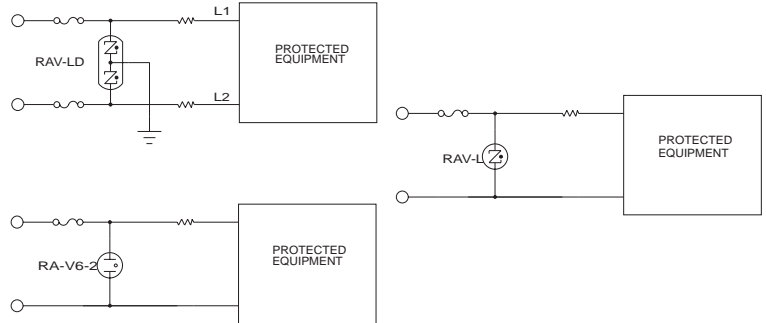

Protecting telecommunications and signal lines

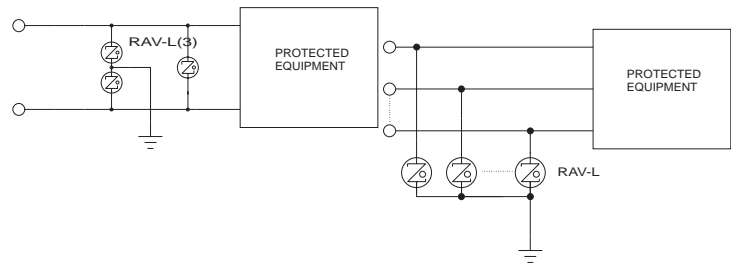

Single phase power supply

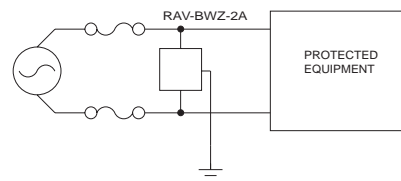

Three-phase inverter power supply

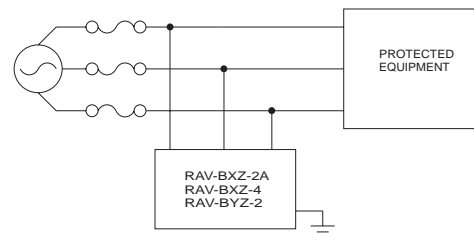

Protecting power supply for vending machine

